

dyson hot+cool

Operating manual
操作手册

HP05

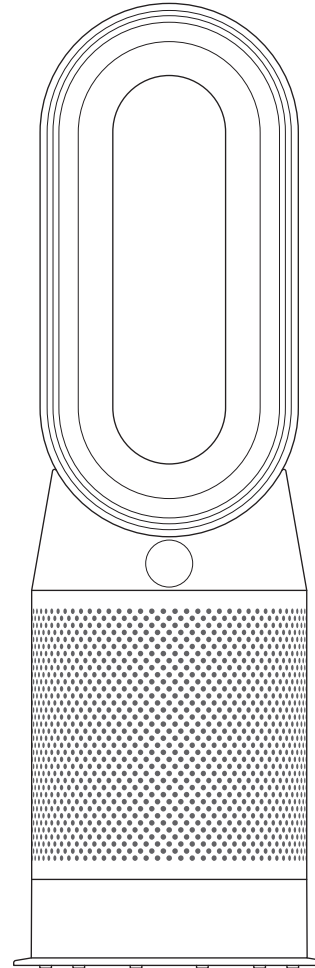

Thank you for choosing to buy
a Dyson purifying fan heater
To read your manual in English
go to page 3.

感谢您选择购买戴森空气净化
暖风扇

如需阅读简体中文版手册, 请转
至第 21 页。

EN

Contents

Getting started

- 5 Registration
- 6 Important safety instructions
- 8 Assembly
- 9 Controls
- 9 Continuous monitoring
- 10 Information menu
- 12 Auto mode
- 13 Heating
- 14 Oscillation
- 15 Airflow
- 16 Sleep Timer
- 17 Night mode

- 17 Care and maintenance
- 18 Additional information

Thank you for choosing to buy a Dyson purifying fan heater

We're here to help



Online
www.dyson.com/support



Support centre
CN: 4009 202 808
CN: china.service@dyson.com

Registration

2 easy ways to register your free 2 year guarantee

After registering your 2 year guarantee, your Dyson appliance will be covered for parts (excluding filters) and labour for 2 years from the date of purchase, subject to the terms of the guarantee. However, indispensable legal rights of the final consumer under applicable national legislation governing the sale of consumer goods are not affected by the terms of the guarantee.

Your serial number can be found on your rating plate which is on the base of the appliance.



Register by phone
Call our dedicated helpline.
CN: 4009 202 808

Note your serial number for future reference.

This illustration is for example purposes only.



Register by email
CN: china.service@dyson.com

IMPORTANT INSTRUCTIONS

WARNING

THE APPLIANCE AND THE REMOTE CONTROL BOTH CONTAIN MAGNETS.

1. Pacemakers and defibrillators may be affected by strong magnetic fields. If you or someone in your household has a pacemaker or defibrillator, avoid placing the remote control in a pocket or near to the device.
2. Credit cards and electronic storage media may also be affected by magnets and should be kept away from the remote control and the top of the appliance.

TO REDUCE THE RISK OF FIRE, ELECTRIC SHOCK, OR INJURY:

3. Disconnect power or unplug before cleaning, performing any maintenance or replacing a filter.
4. Some parts of this appliance can become very hot and cause burns. Particular attention has to be given where children and vulnerable people are present.

5. This appliance is not intended for use by persons (including children) with reduced physical, sensory or mental capabilities, or lack of experience and knowledge, unless they have been given supervision or instruction concerning use of the appliance by a person responsible for their safety. Children should be supervised to ensure that they do not play with the appliance.
6. This appliance must not be located immediately below a socket outlet.
-  7. To avoid the risk of overheating and fire, do not cover this product.
8. If the supply cable is damaged, it must be replaced or repaired by the manufacturer, its service agent or similarly qualified persons in order to avoid a hazard.
9. Do not use this appliance in small rooms when they are occupied by persons not capable of leaving the room on their own, unless constant supervision is provided.
10. To reduce the risk of fire, keep textiles, curtains, or any other flammable material a minimum distance of 1 metre from the air outlet.
11. Only suitable for use in dry environments. Do not use outdoors or on wet surfaces and do not handle any part of the appliance or plug with wet hands. Do not use this appliance in the

- immediate surroundings of a bath, shower or swimming pool.
12. Keep the appliance away from flammable liquids, vapours, air fresheners and essential oils.
 13. Always plug directly into a wall socket. Never use with an extension cable as overloading may result in the cable overheating and catching fire.
 14. Do not use this appliance if it has been damaged or submerged in water.
 15. Do not use this appliance if it has been dropped or if it has visible signs of damage.
 16. Keep this appliance and cable away from heated surfaces. Do not position the cable under furniture or appliances.
 17. Do not put any objects into the air amplifier opening as this may cause an electric shock.
 18. Always carry this appliance by the base and not by the loop amplifier.
 19. Always use this appliance on a horizontal and stable surface.
 20. If there is a loose fit between the plug and the socket or the plug becomes very hot, the socket may need to be replaced. Check with a qualified electrician to replace the socket.
 21. **WARNING: Chemical Burn and Choking Hazard.** Keep batteries away from children.

This product contains a lithium button/coin cell battery. If a new or used lithium button/coin cell battery is swallowed or enters the body, it can cause severe internal burns and can lead to death in as little as 2 hours. Always completely secure the battery compartment. If the battery compartment does not close securely, stop using the product, remove the batteries, and keep it away from children. If you think batteries might have been swallowed or placed inside any part of the body, seek immediate medical attention.

Assembly



Use both hands to lift the appliance out of the box, taking care to hold by the base of the appliance only.

Do not lift out by the amplifier loop.

Slide the buttons down on both sides of the shrouds.

The shrouds will release with the PTFE HEPA filters attached.

Take the carbon filters out of the box and remove the protective packaging.

Attach both carbon filters to the appliance.

Position the shrouds onto the base and push gently until they click securely into place.

Place the remote control on the top of the appliance with the buttons facing down.

Plug in and switch on.

Controls

Remote control

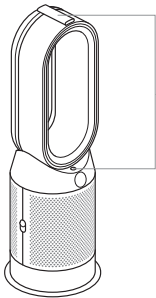

Standby ON/OFF

Standby ON/OFF

Airflow speed

Auto mode

Oscillation ON/OFF

Sleep timer

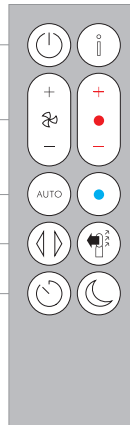

Information menu

Heating control

Cooling mode

Airflow direction

Night mode

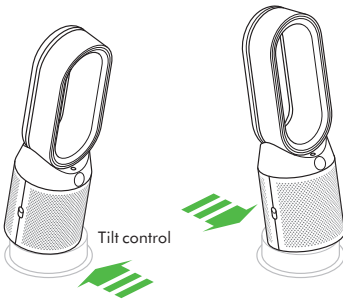

Continuous monitoring

With continuous monitoring enabled, your appliance will gather air quality, temperature and humidity information, which is displayed on the LCD screen.

By default, continuous monitoring is disabled. Once enabled, continuous monitoring is always active.

To enable/disable continuous monitoring:

Press and hold the auto mode button on the remote for 5 seconds to enable it. The LCD screen will indicate when continuous monitoring is enabled or disabled.

Information menu

Press this button to scroll through the information being monitored by your appliance.

Information about air quality, temperature humidity and filter levels are shown.

When a pollutant causes the air quality to drop, the relevant symbol will show on the LCD screen.

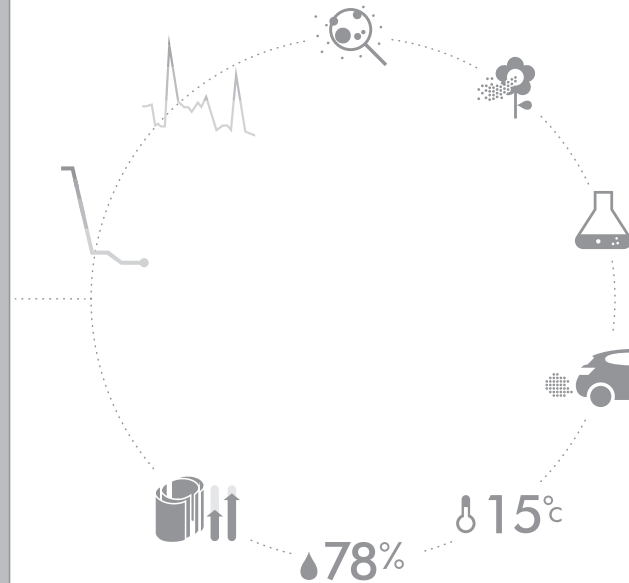
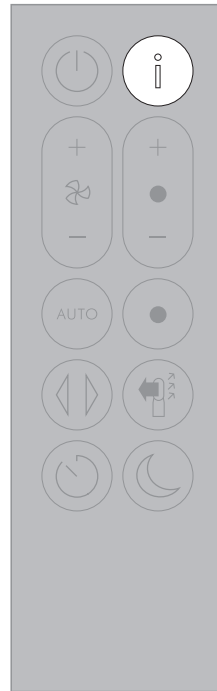



Indoor air quality - 12 seconds
Monitor the current air quality with a graph showing the last 12 seconds of data.



Indoor air quality - 24 hours
Monitors the air quality with a graph showing 24 hours of data, updated at fifteen minute intervals.



Particulate matter (PM2.5)
Monitors the presence of microscopic particles up to 2.5 microns in size, suspended in the air we breathe. These include smoke, bacteria and allergens.



Particulate matter (PM10)
Monitors the presence of larger microscopic particles, up to 10 microns in size, suspended in the air we breathe. These include dust, mould and pollen.



Volatile organic compounds
VOC's are typically odours that may be potentially harmful. These can be found in cleaning products, paints and new furnishings.



Nitrogen dioxide and other oxidising gases
These potentially harmful gases are released into the air by combustion, for example the burning gas when cooking and in vehicle exhaust emissions.



Indoor temperature
Monitor the ambient temperature to help maintain a comfortable environment.



Indoor humidity
Displays the amount of water vapour in the air, shown as a percentage of the maximum possible humidity at the current temperature.



Filters
Displays the remaining lifespan for each filter unit. When a filter needs changing, the display will flash to remind you.

Auto mode

Set your appliance to Auto mode and the on-board sensors will intelligently adjust the settings of the appliance according to the air quality.

Air quality: your appliance will pause when the target air quality has been reached, switching on again when the air quality levels drop.

Airflow speed: The airflow speed will increase until the target air quality and temperature have been reached.

Night mode: Your appliance will only run with Airflow speeds from 1 to 4.

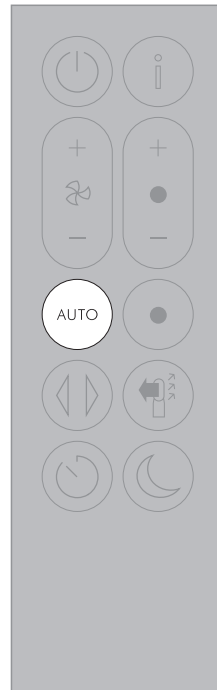

Heating

Press the button to set the required room temperature.

Your appliance will pause when the temperature set has been reached.

Press the Cooling mode button to switch your appliance from Heating mode to Cooling mode.

1-10

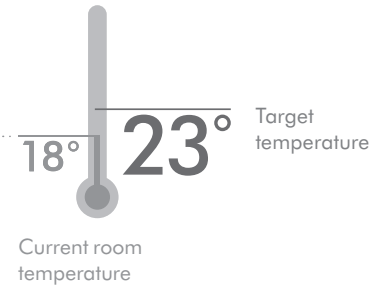
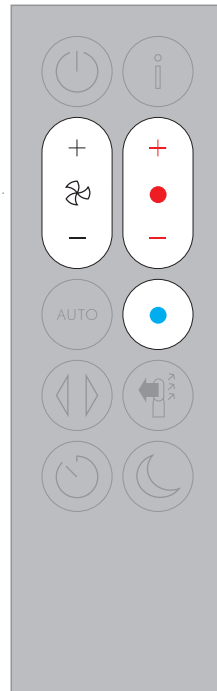

Cooling mode

Oscillation

Press the button to circulate the air around the room and scroll through the oscillation settings from 0° to 350°.

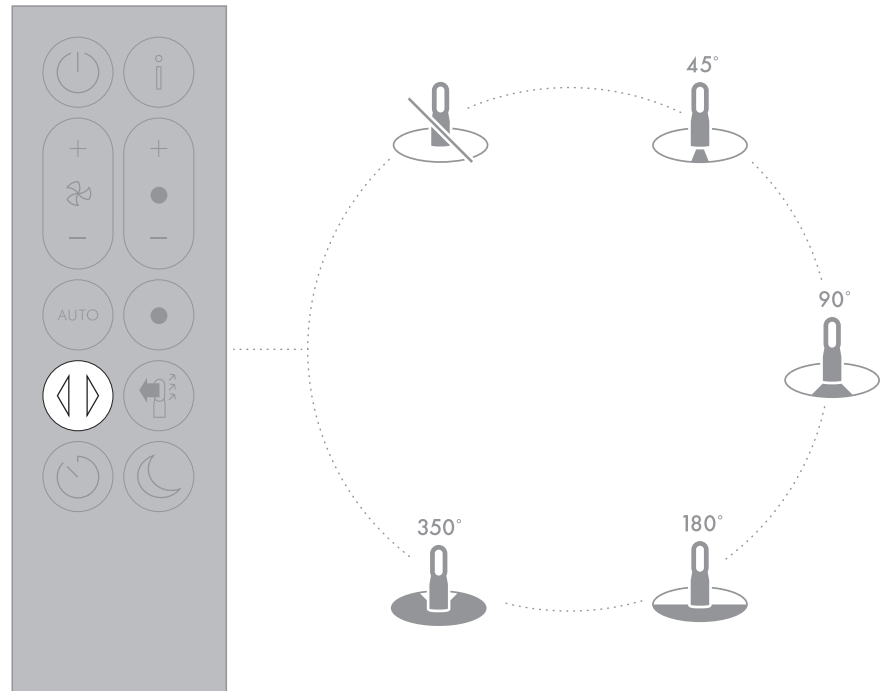

Airflow

Press the Airflow speed button to increase and decrease the airflow speed.

Press the Airflow direction button to change the direction of airflow from front to back. Your appliance will continue to purify in both settings.

Heating mode will only function when the air direction is set to the front. If airflow is changed to the back, your appliance will change to cooling mode.

1-10

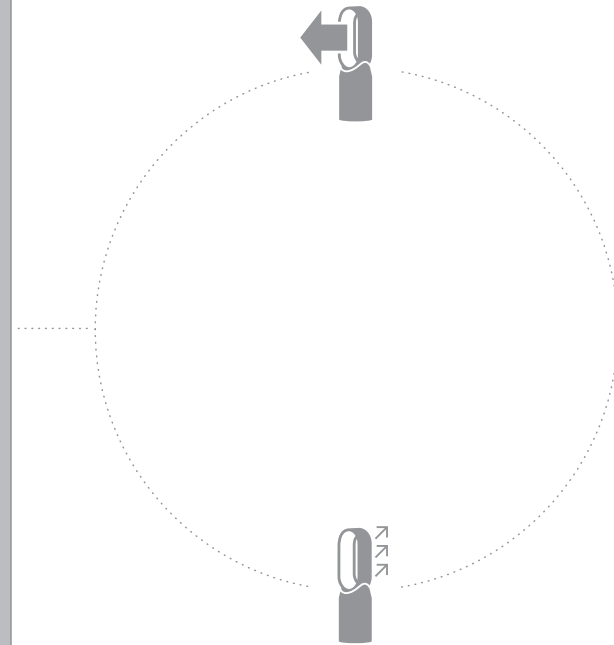

Sleep Timer

Your appliance will turn off automatically after the selected amount of time.

To set the time: Press the button to scroll through the time options. Once activated press the Sleep timer button once to see the time selected.

To cancel the Sleep timer: Press the Sleep timer button twice.

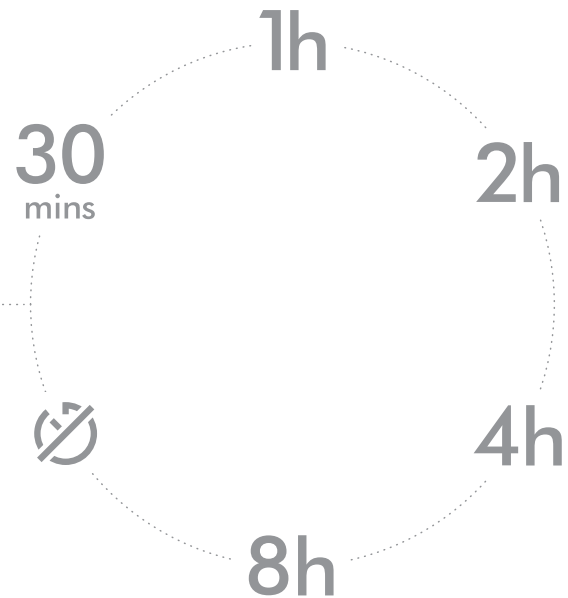
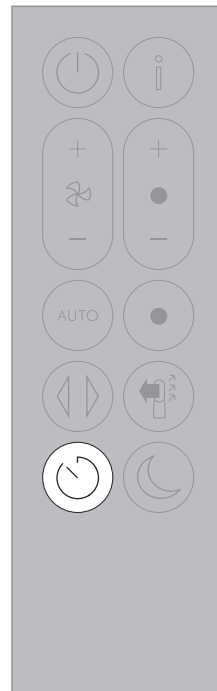

Night mode

In Night mode, your appliance will continue to monitor and respond to changes in air quality and temperature, but only using its quietest settings – and with its LCD screen dimmed.

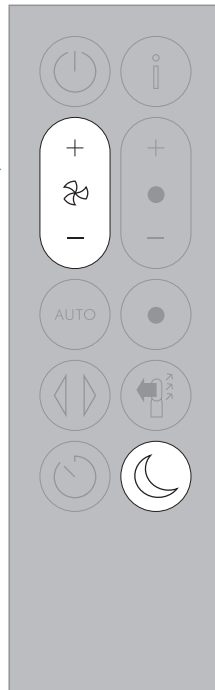

Care and maintenance

To always get the best performance from your appliance, it is important to regularly clean it and check for blockages.

Changing your filters:

The display on your appliance will indicate when to change your filters.

Order new filters online via www.dyson.com. Your new filters will come with instructions, go online for further support and videos.

Do not use your appliance without the filters in place. Unplug your appliance from the mains electricity supply before cleaning or changing filters.

Error codes:

If your appliance shows an error code, try turning it off and then on again. If this does not clear the error code contact Dyson Customer Care.

For further information and support about the care and maintenance of your appliance and replacing the filters go online via:

www.dyson.com

Additional information

Replaceable Parts

Battery replacement

CAUTION

- Unscrew the battery compartment on the remote control. Loosen the base and pull to remove the battery.
- Do not install backwards or short circuit the batteries.
- Do not attempt to dismantle or charge the batteries. Keep away from fire.
- Follow the battery manufacturers' instructions when installing new batteries (battery type CR 2032).
- Always replace the screw in the remote control and refer to the battery hazard in the warning section.

NON-WASHABLE FILTER UNITS

- Your filter units are non-washable and non-recyclable.
- To replace your filter units follow the steps as shown.
- Failure to replace the filter units when prompted may result in changes to product performance and appearance.
- New filter units can be purchased at www.dyson.com/support.

Auto mode

- A period of 6 days is required after the machine is first used for the sensor to calibrate. During this period the machine may be more sensitive to VOCs (such as odours) than normal.
- During first use, whilst the sensors calibrate, the appliance can take up to 60 minutes to show VOC and NO2 data.

Automatic cut-out

- For your safety this appliance is fitted with automatic cut-out switches that operate if the appliance tips over or overheats. If the switches operate, unplug the appliance and allow it to cool. Before restarting the appliance check and clear any blockages and ensure that the appliance is on a solid level surface.
- In heating mode the appliance will automatically switch 'OFF' after 9 hours of continuous use. To restart the appliance, press the Standby ON/OFF button on either the remote control or the base.

Disposal information

- Dyson products are made from high grade recyclable materials. Recycle where possible.
- Dispose of or recycle the battery in accordance with local ordinances or regulations.
- Keep the used batteries away from children as these can still harm children if swallowed.
- Your filter units are non-washable and non-recyclable.
- Dispose of the exhausted filter units in accordance with local ordinances or regulations.
- The battery should be removed from the product before disposal.

Dyson customer care

Thank you for choosing to buy a Dyson appliance

After registering your 2 year guarantee, your Dyson appliance will be covered for parts (excluding filters) and labour for 2 years from the date of purchase, subject to the terms of the guarantee. However, indispensable legal rights of the final consumer under applicable national legislation governing the sale of consumer goods are not affected by the terms of the guarantee. If you have any queries regarding your Dyson appliance, visit www.dyson.cn/supportcn for online help, general tips and useful information about Dyson.

Alternatively, you can call the Dyson Helpline with your serial number and details of where and when you bought the appliance.

Your serial number can be found on your rating plate which is on the base of the appliance. If your Dyson appliance needs a service, call the Dyson Helpline so we can discuss the available options. If your Dyson appliance is under guarantee, and the repair is covered, it will be repaired at no cost.

PLEASE REGISTER AS A DYSON APPLIANCE OWNER

To help us ensure that you receive prompt and efficient service, please register as a Dyson appliance owner. There are two ways to do this:

- By email: china.service@dyson.com
- By calling the Dyson Helpline.

This will confirm ownership of your Dyson appliance in the event of an insurance loss, and enable us to contact you if necessary.

LIMITED 2 YEAR GUARANTEE

TERMS AND CONDITIONS OF THE DYSON 2 YEAR LIMITED GUARANTEE

What is covered

- The repair or replacement of your Dyson appliance (at Dyson's discretion) if it is found to be defective due to faulty materials, workmanship or function within 2 years of purchase or delivery (if any part is no longer available or out of manufacture, Dyson will replace it with a functional replacement part).
- This guarantee will only be valid if the appliance is used in the country in which it was sold.

What is not covered

• Replacement filter units. The appliance's filter units are not covered by the guarantee. Dyson does not guarantee the repair or replacement of an appliance where a defect is the result of:

- Damage caused by not carrying out the recommended appliance maintenance.
- Accidental damage, faults caused by negligent use or care, misuse, neglect, careless operation or handling of the appliance which is not in accordance with the Dyson Operating Manual.
- Use of the appliance for anything other than normal domestic household purposes.
- Use of parts not assembled or installed in accordance with the instructions of Dyson.
- Use of parts and accessories which are not genuine Dyson components.
- Faulty installation (except where installed by Dyson).
- Repairs or alterations carried out by parties other than Dyson or its authorised agents.
- Blockages – Please refer to the 'Troubleshooting' section and illustrations in this Dyson Operating Manual for details of how to look for and clear blockages.
- Normal wear and tear (e.g. fuse etc.).
- Reduction in battery discharge time due to battery age or use (where applicable).

If you are in any doubt as to what is covered by your guarantee, please contact Dyson.

Summary of cover

- The repair or replacement of your Dyson appliance under guarantee will not extend the period of guarantee.
- The guarantee provides benefits which are additional to and do not affect your statutory rights as a consumer.
- The guarantee becomes effective from the date of purchase (or the date of delivery if this is later).
- You must provide proof of (both the original and any subsequent) purchase/delivery before any work can be carried out on your Dyson appliance. Without this proof, any work carried out will be chargeable. Keep your receipt or delivery note.
- All work will be carried out by Dyson or its authorised agents.
- Any parts which are replaced by Dyson will become the property of Dyson.

Privacy and Personal Data Protection

When registering your Dyson appliance:

- You will need to provide us with basic contact information to register your appliance and enable us to support your guarantee.
- When you register, you will have the opportunity to choose whether you would like to receive communications from us. If you opt-in to communications from Dyson, we will send you details of special offers and news of our latest innovations. We never sell your information to third parties and only use information that you share with us as defined by our privacy policies which are available on our website: privacy.dyson.com

CN

目录

开始使用

- 23 注册
- 24 重要安全信息
- 26 组装
- 27 控制
- 28 信息菜单
- 30 自动模式
- 31 暖风模式
- 32 环绕设置
- 33 气流方向
- 35 睡眠定时
- 34 夜间模式

- 35 保养和维护
- 36 其他信息

感谢您选择购买戴森空气净化暖风扇

我们在此提供帮助



在线方式
www.dyson.cn/support



支持中心
CN: 4009 202 808
CN: china.service@dyson.com

注册

2 种注册 2 年免费保修的简单方法

登记获取2年保修后, 您的戴森产品自购买之日起将享受2年的产品保修(含零件及人工, 滤网除外), 但须符合保修条款的规定。但是, 最终消费者依据产品销售所适用的国家法规享有不可撤销的合法权利, 此类权利不受保修条款规定的影响。

在您的铭牌上可以找到序列号, 铭牌位于产品的主机底部。

请记录您的产品序列号, 以备日后查用。

本图仅供示例之用。



通过电话注册
请致电我们的专用服务热线。
CN: 4009 202 808



通过电子邮件注册
CN: china.service@dyson.com

重要的安全说明

警告

风扇和遥控器中均包含磁体。

1. 强磁场可能会对电子起搏器和心脏除颤器造成影响。如果您或您的家人使用电子起搏器或心脏除颤器，请勿将遥控器放在口袋里或靠近这些设备。
2. 磁场也会对信用卡或电子存储媒介造成影响，应使这些物品远离遥控器和产品的顶部。
为降低火灾、触电及受伤的危险：
3. 在清洁或执行任何维护，以及更换滤网前，请断开电源或拔下插头。
4. 本产品的某些部件可能会变得很烫并造成烫伤。有儿童和老弱伤残在场时，应特别小心。
5. 本产品不适合身体、感觉或智力残障人士（包括儿童）以及缺乏相关经验和知识的人员使用，除非其责任人提供监督或就产品的安全使用提供指导。请照看好儿童，确保他们不会玩弄本产品。
-  6. 本产品不得直接置于电源插座下面。
7. 为了避免过热和发生火灾的危险，请勿遮盖本产品。

8. 一旦电源线损坏，必须由制造商、其服务代理商或具有相关资质的人员来进行更换或维修，以免发生危险。
9. 除非提供持续的监督，否则不可在无法自行离开者所处的小房间内使用本产品。
10. 为降低火灾风险，请将纺织品、窗帘或任何其他易燃材料与出风口保持至少 1 米的距离。
11. 仅适合在干燥环境下使用。请勿在室外或潮湿表面上使用。请勿在浴室、洗衣房或类似的室内空间使用。请勿将本产品放置在可能掉入浴缸或其他盛水容器中的位置。请勿在可能使其潮湿或直接靠近浴缸、喷头或游泳池的位置使用或存放本产品。
12. 使本产品远离易燃的液体、蒸汽、空气清新剂和精油。
13. 始终直接将插头插入墙壁插座。请勿使用电源延长线，因为过载可能造成电源线温度过高，从而引起火灾。
14. 如果本产品已损坏或浸水，请勿使用。
15. 如果本产品跌落或有明显的损坏迹象，请勿使用。
16. 请保持本产品和电源线远离加热的表面。请勿在家具或产品下面放置电源线。
17. 请勿将任何物体放入空气倍增器开口中，因为这可能会导致触电。
18. 务必通过底座而不是环路放大器拿起本产品。
19. 务必在水平稳定的表面上使用本产品。

20. 如果插头与插座之间出现松动, 或者插头变得很烫, 则可能需要更换插座。咨询有资质的电工以更换插座。
21. 警告: 化学烧伤和窒息危险。使电池远离儿童。本产品包含纽扣/硬币型锂电池。如果新的或废旧纽扣/硬币型锂电池被误吞或进入体内, 可能会导致严重的内部烧伤, 并在短至 2 小时内导致死亡。请确保电池盖完全安全。如果电池盖未安全闭合, 请停止使用产品, 取下电池, 并使其远离儿童。如果认为电池可能已被吞下或放入身体任何部位, 请立即就医。

组装

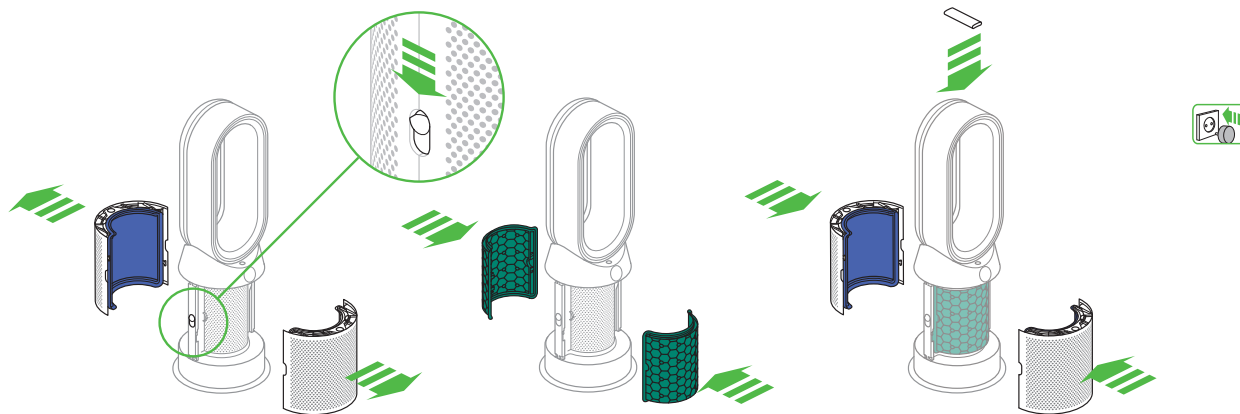

使用双手将产品从箱中提出，注意只能握住产品的底座。

请勿提拉风环将产品取出。

将护罩上两侧上的按钮向下滑动。

将护罩和 PTFE HEPA 滤网一起松开拆下。

将活性炭滤网从箱中取出，并去除保护包装。

将两个活性炭滤网衔接至护罩。

将护罩放置到底座上，并轻轻推动，直到其牢固卡扣到位。

将遥控器置于产品顶部，按钮面朝下。

插入电源并开机。

控制

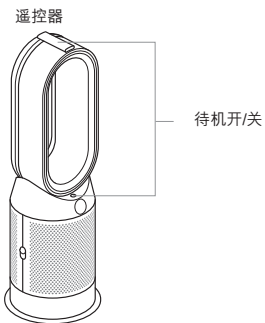

待机开/关

气流速度

自动模式

环绕开/关

睡眠定时

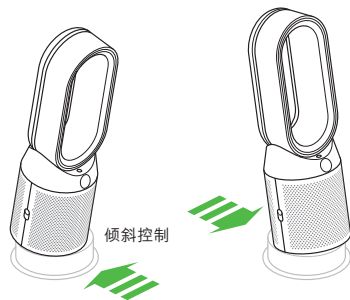
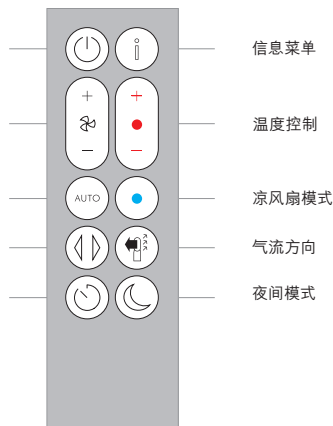

持续监测

持续监测功能开启后, 设备将收集空气质量, 温度, 湿度信息并显示在液晶屏幕上。

默认情况下, 持续监测功能关闭。开启后, 持续监测功能将始终处于开启状态。

开启/关闭持续监测功能:

按住遥控器上的自动模式按钮5秒可开启该功能。开启或关闭持续监测功能时, LCD屏幕将予以提醒。

信息菜单

按下该按钮来滚动浏览您的产品监测到的信息。

产品会显示关于空气质量、温度、湿度和过滤水平的信息。

如果某种污染物导致空气质量下降, 则相关的符号会显示在 LCD 屏幕上。

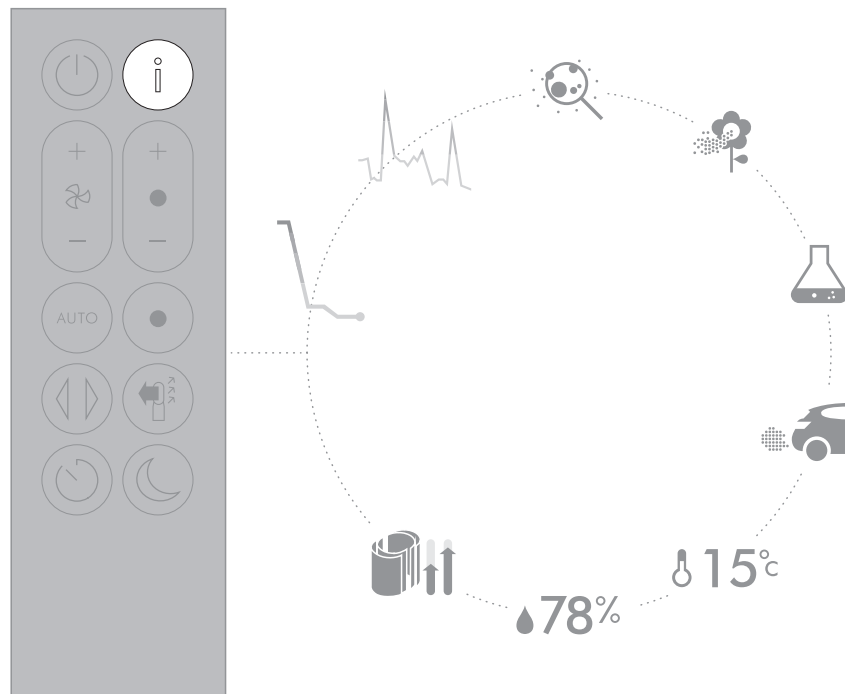



室内空气质量 - 12 秒
显示过去12秒空气质量指数。



室内空气质量 - 24 小时
每15分钟更新数据，显示24小时空气质量指数。



可吸入颗粒物 (PM2.5)
能监测悬浮在空气中尺寸小于等于2.5微米的可吸入颗粒物含量。这些颗粒物包括烟雾、细菌和部分过敏原等。



可吸入颗粒物 (PM10)
能监测悬浮在空气中尺寸小于等于10微米的可吸入颗粒物含量。这些颗粒物包括灰尘、霉菌等。



**挥发性有机化合物
VOC** 通常是潜在有害的气味。这些物质存在于清洁产品、油漆和新家具中。



二氧化氮和其他氮氧化物
这些气体是潜在有害的气体，通过燃烧释放到空气中，例如烹饪时的燃气废气，以及车辆尾气。



室内温度
监测室内温度，帮助维持舒适的环境。



室内湿度
显示当前温度下室内可能的相对湿度。

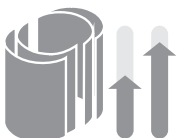

滤网
显示每个滤网装置的剩余寿命。在需要更换滤网时，显示屏将会闪烁以提醒您。

暖风模式

按下按钮以设置所需的室温。

您的产品将在达到设定的温度之后
暂停。

按下凉风扇模式按钮，将您的产品从
暖风模式切换为凉风扇模式。

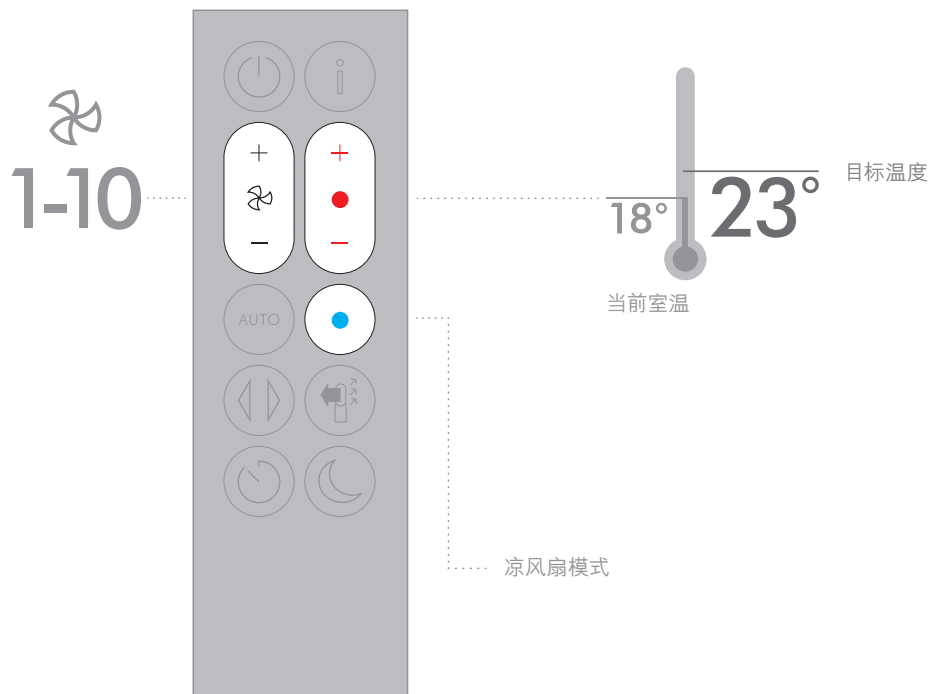

环绕设置

按下按钮让空气在房间中循环，并
可从 0° 到 350° 滚动选择环绕
设置。

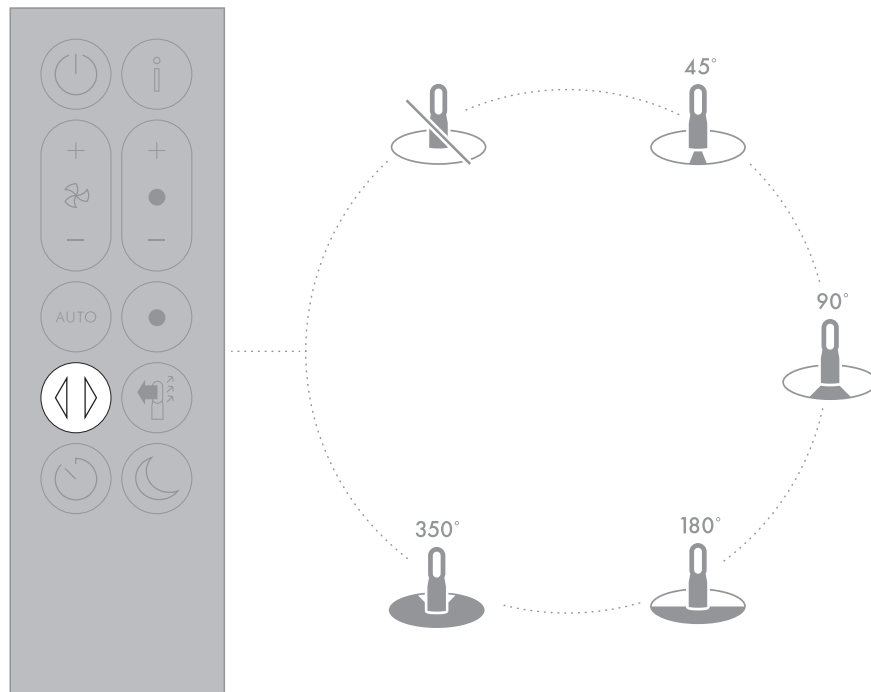

气流方向

请使用风速调节按钮来调高和降低风速。

按下气流方向按钮将气流方向从前方更改到后方。在两种设置下，产品都能继续净化空气。

暖风模式仅在气流方向设置为向前喷射时工作，如果气流方向更改为后方，本产品将切换至凉风扇模式。

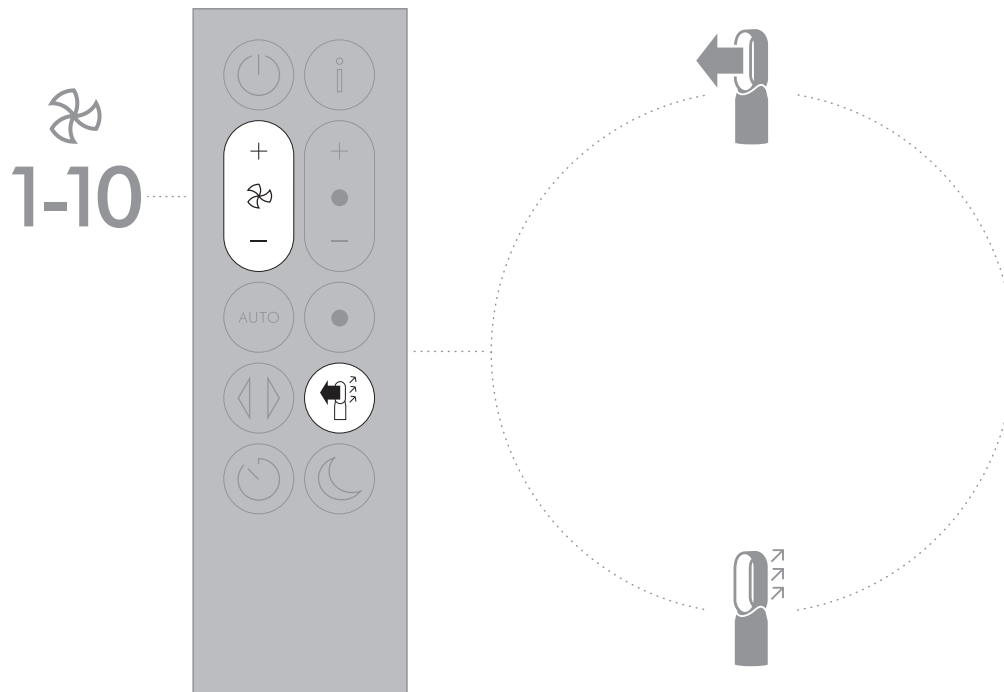

睡眠定时

本产品将会在经过所选的时间后自动关闭。

设置该时间的方法：按下按钮滚动选择时间选项。一旦激活，按下睡眠按钮可看到所选的时间。

取消睡眠定时器的方法：按下睡眠定时器按钮两次。

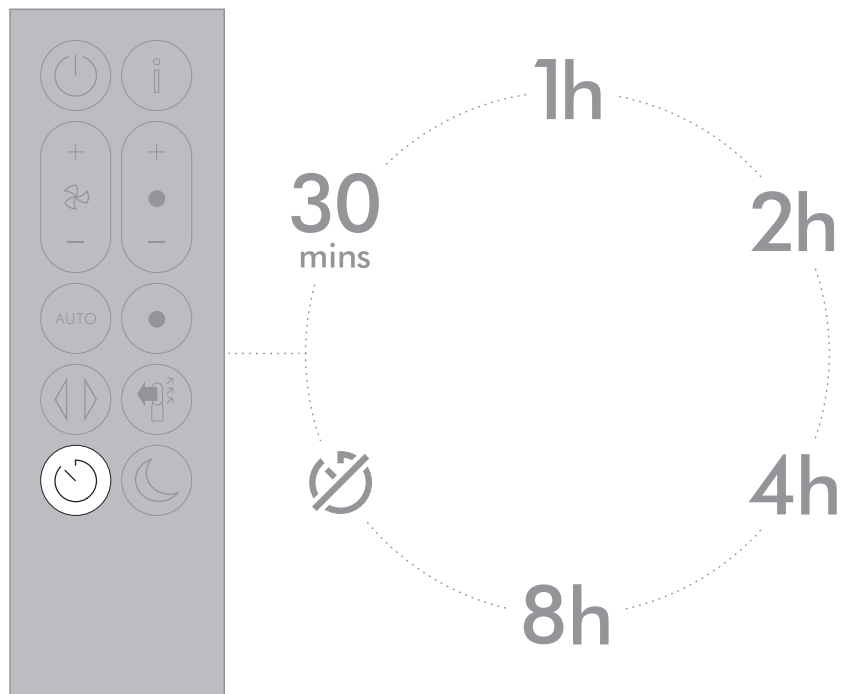

夜间模式

在夜间模式下，本产品将继续监视和响应空气质量上的变化，但只会用最安静的设置，并且会调暗LCD屏幕。

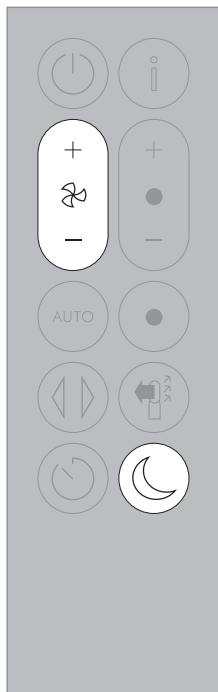

保养和维护

为了让产品始终发挥最佳性能，定期清洁产品并检查堵塞情况十分重要。

更换您的滤芯：

需要更换滤芯时，设备显示屏会有提示。

您可以在www.dyson.com网站上购买。滤网会配有介绍，更多的支持资料和视频请浏览网站获得。

未装妥滤芯时，请勿使用本产品。在清洁或更换滤芯之前，将产品插头从主电源上拔下。

错误代码：

如果您的产品显示错误代码，请尝试将其关闭，然后再次打开。如果该操作无法清除错误代码，请联系戴森客户关怀部门。

更多关于设备和滤网的关怀和保养信息，请浏览网站：

www.dyson.com

其他信息

可更换零件

更换电池

注意事项

- 拧下遥控器上的电池盖。松开底座，将电池取出。
- 请勿反装电池，可能导致电池短路。
- 请勿尝试拆解电池或为电池充电。远离火源。
- 安装新电池时，请遵照电池制造商的说明操作（电池型号为 CR 2032）。
- 请务必装回遥控器上的螺丝，并参照在警告部分有关电池危险的描述。

不可清洗滤网

- 产品的滤网是不可清洗和不能回收的。
- 更换滤网必须要遵循说明书中的指示。
- 不及时更新滤网可能导致产品性能和外观变化。
- 新的滤网可以在www.dyson.cn/support 上购买。

自动模式

- 本产品初次使用后的 6 天里，传感器会持续校准。在此期间，对比正常工作状态下，机器可能会对于 VOCs（挥发性有机化合物，例如异味）更加敏感。
- 在首次使用期间，在传感器校准时，本产品最多需要 60 分钟方可显示 VOC 和 NO2 数据。

自动断电

- 为了确保人身安全，机器上安装了自动断电开关，可在机器倾倒或过热时自动关闭。如果触发此开关，请拔出机器插头并使其冷却。在重新启动机器前请检查并清除任何阻塞物，并且确保将其放置在坚硬的水平表面。
- 在加热模式，在持续使用 9 小时后，产品会自动关闭。如果需要从新启动，需要按待机开关按钮或用遥控器开启。

处置信息

- 戴森产品使用高级别可回收材料制成。请尽可能进行循环利用。
- 处置电池或者再循环利用电池时，需遵循当地的法令或规章。
- 应使废旧电池远离儿童，因为吞咽后仍会对儿童造成危害。
- 产品的滤网是不可清洗和不能回收的。
- 处理废弃的滤网时，需遵循当地的法令或法规。
- 在废弃器具前，必须将电池从器具中取出。在取出电池时，器具必须要断电。电池应安全地处置。

戴森客户服务

感谢您选择购买戴森产品。

登记获取 2 年保修后，您的戴森产品自购买之日起将享受 2 年的产品保修（含零件及人工，滤网除外），但须符合保修条款的规定。但是，最终消费者依据产品销售所适用的国家法规享有不可撤销的合法权利，此类权利不受保修条款规定的影响。关于戴森产品，如果您有任何问题，请访问www.dyson.cn/supportcn 以获取有关戴森产品的在线帮助、一般信息提示和其他有用的信息。

或者，请拨打戴森客户服务热线，提供给我们产品序列号和购买产品的详细时间和地点。在您的铭牌上可以找到序列号，铭牌位于产品的主机底部。如果您的产品需要修理，请致电戴森帮助热线，以便我们讨论可能的方案。如果您的产品在保修期内，且属于保修范围，将会免费修理。

在您的铭牌上可以找到序列号，铭牌位于产品的主机底部。

如果您的产品需要修理，请致电戴森帮助热线，以便我们讨论可能的方案。如果您的产品在保修期内，且属于保修范围，将会免费修理。

请注册为戴森用户

为确保您收到及时有效的服务，有 2 种方法进行登记：

- 电子邮箱保修注册 CN: china.service@dyson.com
- 致电戴森客户帮助热线。

如果发生保险损失情况，这样做可以确定您对戴森产品的所有权，并且让我们在必要时与您联系。

2 年有限保修

戴森 2 年有限保修的条款与条件

保修范围

- 除非法律另有规定，如果在购买或交付的 2 年内发现戴森产品存在材料、制造或功能缺陷，将为您维修或更换（由戴森决定）戴森产品（如果任何部件不可获取或不再制造，戴森将为您更换功能相当的替换部件）。
- 本保修仅当产品在售出时使用方有效力。

不保修范围

- 更换滤网不在保修的范围。
- 戴森不保证以下原因导致的产品修理或更换：
 - 由于不执行建议的产品维护而导致的损坏。
 - 由于使用时不小心、误用、疏忽、粗鲁操作或以任何违反戴森操作手册的方式操作戴森产品所造成的意外损坏和故障。
 - 将产品用于任何正常居家使用之外的目的。
 - 使用的零件未按戴森指导说明进行组装或安装。
 - 使用非戴森原厂的零件和附件。
 - 错误安装（戴森安装的除外）。
 - 非戴森或其授权代理所执行的维修或改动。
 - 阻塞物 有关如何检查并清除阻塞物的详细信息，请参阅本戴森操作手册中的图示和“故障排除”部分。
 - 正常磨损和损耗（例如，保险丝等）。

- 由于电池老化或使用而导致电池放电时间缩短（仅无绳产品）。

如果您对保修范围有任何疑问, 请致电戴森热线。

保修范围概要

- 保修自购买（或交付, 若交付时间略晚于购买时间）之日起生效。
- 在您的戴森产品接受任何处理前, 您必须提供（初次及任何后续）交货/购买的证明材料。若无此证明材料, 任何处理都将会收费。请妥善保管您的收据或提货单。
- 所有工作都将由戴森或其授权代理商完成。
- 任何更换的部件将归戴森所有。

个人隐私信息保护

注册戴森产品时:

- 您需要向我们提供基本联系信息, 方可注册您的产品, 使我们能支持您的保修。
- 注册时, 您可以选择是否从我们这里接收通讯。如果您同意接收戴森的通讯, 我们将向您发送特别优惠详情和最新发明及创新产品方面的新闻。我们决不会将您的信息出售给第三方, 只会按我们隐私政策的规定使用您与我们分享的信息, 政策内容可在我们网站上找到: privacy.dyson.com

有害物质或元素名称及含量标识

Marking for Name & Content of Toxic or Hazardous Substances or elements

部件名称 Part Name	Hazardous Substances or elements 有害物质或元素					
	镉 (Cd) Cadmium	铅 (Pb) Lead	汞 (Hg) Mercury	六价铬 (Cr(VI)) Hexavalent Chromium	多溴联苯(PBB) Polybrominated biphenyls	多溴二苯醚 (PBDE) Polybrominated diphenyl ethers
外壳, 机身 External chassis, body	○	○	○	○	○	○
内部机架 Internal chassis	○	○	○	○	○	○
控制器及其部件 Controller & parts	○	○	○	○	○	○
印刷电路板及电 子部件 Printed circuit board & components	○	X ⁽¹⁾	○	○	○	○
电机组件 Motor Assembly	○	X ⁽¹⁾	○	○	○	○
加热器组件 Heater Assembly	○	X ⁽¹⁾	○	○	○	○
热断路器陶瓷部件 Ceramic part in Thermal Cut-out	○	X ⁽¹⁾	○	○	○	○
粉尘传感器 Dust Sensor	○	X ⁽¹⁾	○	○	○	○

本表格依据SJ/T 11364的规定编制

The table is compiled in accordance to SJ/T 11364 standard

○:表示该有害物质在该部件所有均质材料中的含量均在GB/T 26572规定的限量要求以下
○: Indicate that this hazardous substance contained in all of the homogeneous materials for this part is within the limit requirement in GB/T 26572.

X:表示该有害物质至少在该部件的某一均质材料中的含量超出GB/T 26572规定的限量要求
X: Indicate that this hazardous substance contained in at least one of the homogeneous materials used for this part exceed the limit requirement in GB/T26572

(1) 部件材质中有害物质含量符合欧盟RoHS指令豁免项目的限值(2011/65/EU)

(1) Hazardous substance contained is exempted under EU RoHS directives exemption list (2011/65/EU)

声明:

环保使用期限的参考标识取决于产品正常工作的温度和湿度等条件

Disclaimer:

The environment safe use period is declared based on the normal temperature & humidity use conditions.



Dyson customer care

If you have a question about your Dyson appliance, contact us via the Dyson website or call the Dyson Helpline with your serial number and details of where and when you bought the appliance.

戴森客户关怀

关于戴森产品, 如果您有任何问题, 请通过网站与我们联系或者拨打戴森客户关怀热线, 将产品序列号和购买产品的详细时间和地点信息提供给我们。

CN

戴森贸易(上海)有限公司

china.service@dyson.com

4009 202 808

上海市黄浦区汝南街63号主楼103a + 1M单元

www.dyson.cn

www.dyson.com

JN:97361 PN:270694-01-02 29.08.18